

About CHMER

Established in 1975, CHMER is the largest EDM manufacturer in Taiwan, exporting over 55 countries. Product lines include Die Sinking EDMs, Wire Cut EDMs, Small Hole Drilling EDMs, High Speed Milling Machines, and Laser Machines. A comprehensive technical support completes our services.

Environmental Requirements

1. Ideal temperature-controlled room: $23 \pm 0.5^{\circ}\text{C}$; Humidity: below 75% RH
2. Avoid placing the machine near vibrating sources or sources of impact energy, such as floors with heavy machinery
3. Avoid placing the machine under direct sunlight
4. Avoid placing the machine near heat processing equipment or magnetic fields, as the controller's sensitive electronic components may be affected
5. Avoid placing the machine in dusty environments, which may impact the machine structure and components

Space Requirements

Ensure sufficient space around the machine for maintenance access and operational movement.

Grounding Work

1. To prevent electromagnetic interference and leakage, follow Class 3 grounding regulations (ground resistance below 10Ω) as specified in the electrical equipment standards, and connect to other machines' grounding points
2. Use an independent grounding wire of 14 mm^2

Air Pressure Requirements

1. Only machines equipped with AWT (Auto Wire Threading) or immersion-type models require air pressure: 6 kg/cm^2



High Precision Linear Motor Drive Wire Cut EDM

INTELLIGENCE x FUTURE



NV Series Wire Cut EDM

WNV000Ev01



慶鴻機電工業股份有限公司
CHING HUNG MACHINERY & ELECTRIC INDUSTRIAL CO., LTD.

No.3, JingKe 1st Rd., Nantun Dist., Taichung City 408, Taiwan

TEL / 886-4-2350-9188 FAX/ 886-4-2350-0977

<http://www.chmer.com>

Wire Cut•Die Sinking•Drilling•High Speed Milling•Laser Machine

Shaping the Future of Smart Manufacturing

Smart Future



The NV Series is engineered to meet the highest demands in machining accuracy, speed, and performance, enabling a significant boost in productivity.

Its streamlined design combines simplicity with craftsmanship, with every detail reflecting a customer-oriented mindset to ensure perfection and deliver an exceptional user experience.

Choose the NV Series Wire Cut EDM and discover the perfect fusion of performance and design.



Machine Design

01 High Rigidity Structural Design

Featuring a trapezoidal base combined with a moving-type XY axis structure, the machine ensures a stable low center of gravity. The worktable maintains stability at any position, delivering outstanding machining stability and accuracy.

02 Extended Z-Axis Travel (Opt.)

To accommodate high-thickness workpieces or special cutting with the 6th axis, an optional extended Z-axis travel is available to meet the requirement for increased clearance.

03 Triple Guideway Design (NV643 Model)

The unique triple linear guideway structure ensures exceptional stability during saddle and upper frame movements, achieving superior machining stability and accuracy.

04 Automatic Rise-and-Fall Tank Door

With a simple press or a program, the tank door automatically rises or lowers for quick access. The automatic locking ensures safety during machining, significantly enhancing work efficiency and saving space—making it an ideal feature for automation.

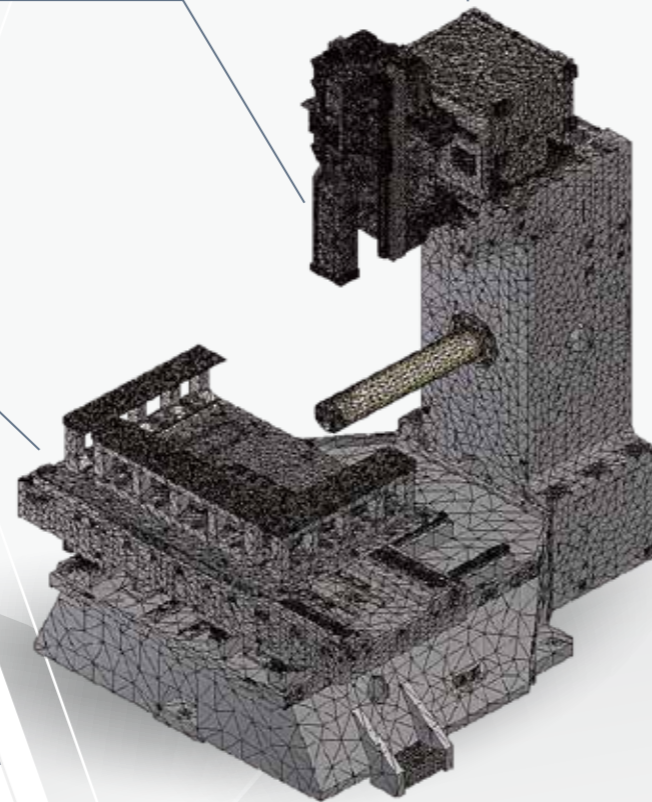

6th Gen AWT

5th vs. 6th Gen AWT System

Item	Unit	AWT 5.5	AWT 6th	Diff. %
Threading Time	sec	12	9	-25%
Wire Cutting Time	sec	4.5	2.5	-44%
Heater Lifetime	mth.	4	8	100%
Heater Power Consumption	W	5.5	4.5	-18%
Circuit Board Count	pcs	7	5	-28%
AWT System Power Usage	W	320	165	-48%

Backed by years of automation experience, CHMER introduces the enhanced 6th Gen AWT system. It shortens wire threading and cutting time by over 20%, extends consumable lifespan by more than 100%, and reduces overall power consumption by 48%.

01

Intuitive Parameter Adjustment Interface

Offers 50 copper wire parameter sets. Simply select the suitable one for different wire brands and diameters to ensure excellent threading performance.

02

3999 Programmable Hole Machining Records

Capable of storing up to 3999 hole machining records for easy access to multi-hole data.

03

Break point Re-threading Function

After a cutting interruption, threading resumes at the break point for immediate machining—no need to return to the start, reducing idle travel time.

04

Wire Threading Assistant Device

Enhances threading success for high thickness through Auto Threading Assistant Device

Features

- ✓ The highly reliable mechanical design reduces maintenance costs, achieving an almost 100% wire threading success rate.
- ✓ Equipped with broken wire detection and submerged threading functions, it minimizes the time required for restarting from the cutting point, draining, and refilling. Based on machining conditions, it enables unmanned operation and smart manufacturing.
- ✓ The threading execution mode can be freely set, and with the wire threading assistance device, threading thick workpieces is no longer a concern.
- ✓ With the integration of automatic water level control, multiple uneven height machining tasks can also be fully automated.

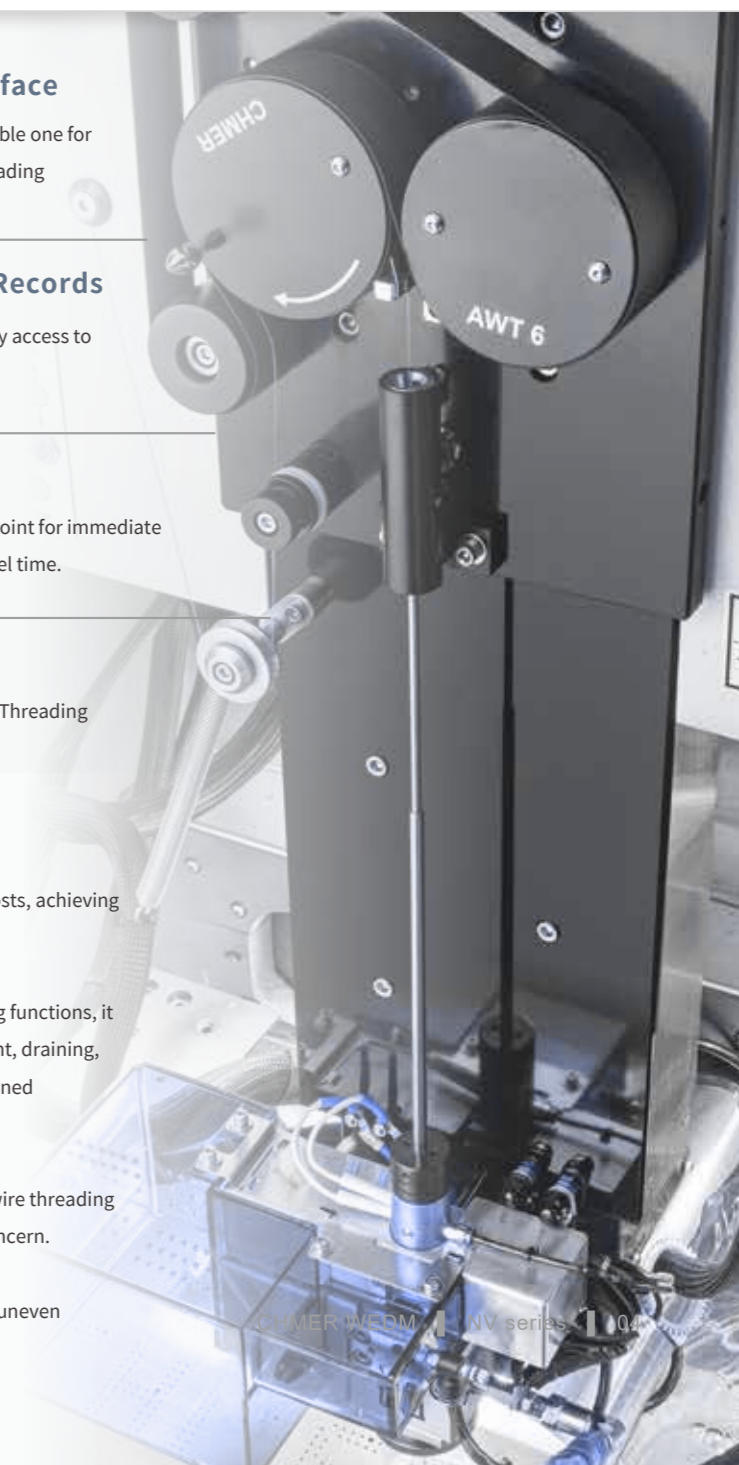

Linear Motor

All models are equipped with CHMER's UX1 linear motor drive system, delivering stronger thrust with lower energy consumption to ensure stable and accurate movement every time. It features zero friction, no backlash, no transmission loss, no vibration, and excellent responsiveness.

UX1 Linear Motor

Engineered with a dual-balanced design that delivers high thrust, low heat generation, and maintenance-free operation, while ensuring the structure remains unaffected by magnetic forces.

Integrated with the latest 24-bit high-performance drive, the linear motor achieves a threefold increase in response frequency. This ensures higher speed, superior responsiveness, precise positioning, exceptionally smooth stability, and accurate feedback.

It guarantees consistent stability and accuracy in every movement while reducing overall energy consumption.

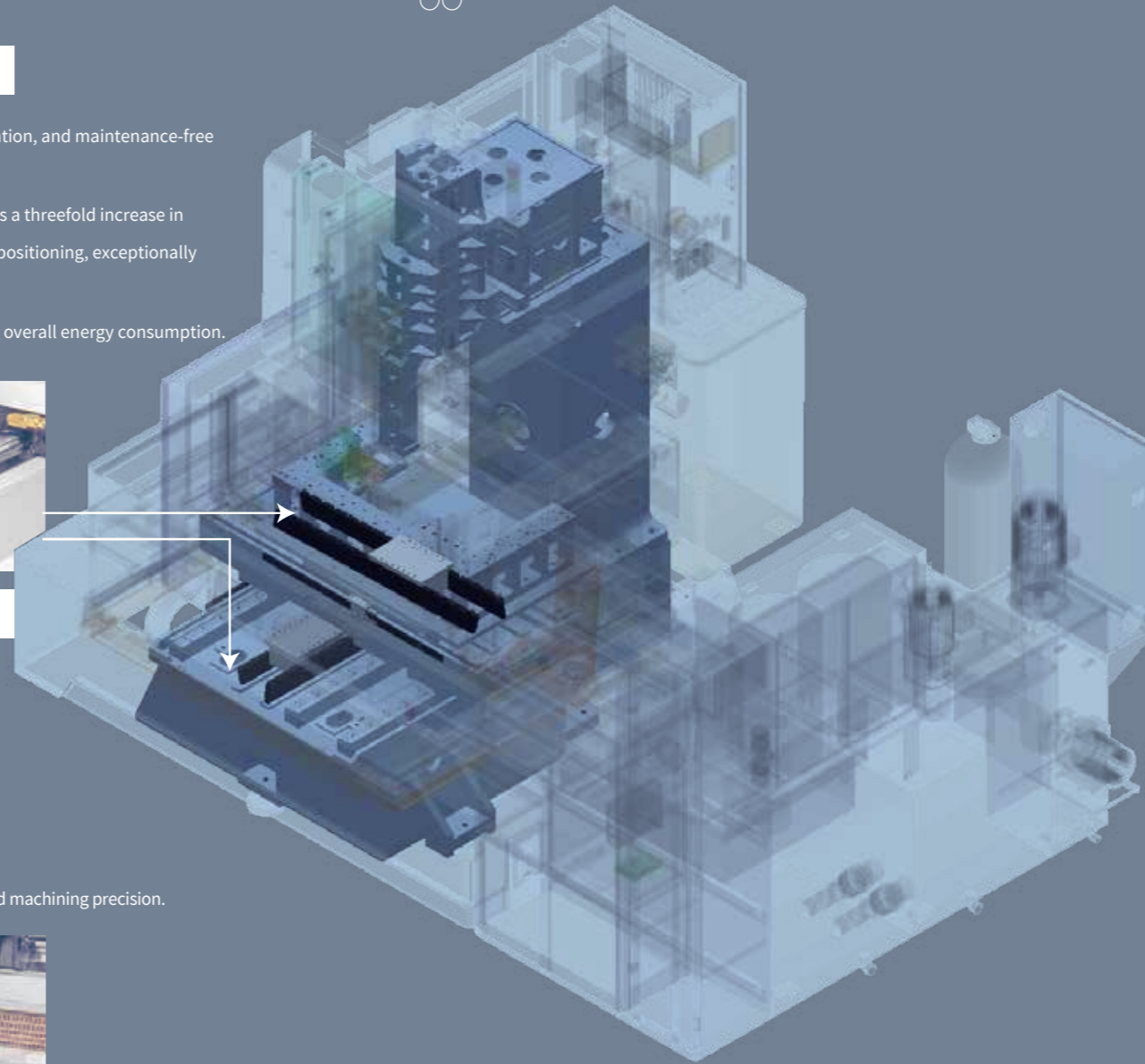

Absolute Linear Scale

- 01 **Excellent Anti-Interference :**
Provides superior resistance to interference and contamination.
- 02 **No Reference Return Required :**
Eliminates the need to return to a reference point at every startup.
- 03 **High Accuracy :**
Delivers higher positioning detection accuracy, contributing to improved machining precision.



Reduction of the tolerance on shape accuracy

Especially at the intersection of straight line to curve

	Linear Motor		BallscREW	
	Section A	Section B	Section A	Section B
Top	5.999	3.999	5.999	3.998
Middle	6.000	3.998	5.998	3.995
Bottom	6.000	4.000	6.000	3.999
Tolerance	-0.001	-0.002	-0.002	-0.005

《Machining Conditions》

- Brass wire = 0.20 mm/BS
- Workpiece=SKD11
- Thickness=50 mm
- Number of cuts=3

《Cutting Profile》



Enhanced Surface Accuracy

- Brass wire = 0.20 mm/BS
- Number of cuts = 5
- Surface roughness = Ra 0.25 μm
- Workpiece = SKD11
- Thickness = 25 mm

When equipped with the optional AC-μ Super Fine Finish Circuit, the linear motor system significantly enhances finishing speed, surface uniformity, and detailing. With speed deviation under 10%, it achieves superior surface finishes beyond the capabilities of traditional ballscrew systems.

Ballbar Testing

After 5 Years of Use

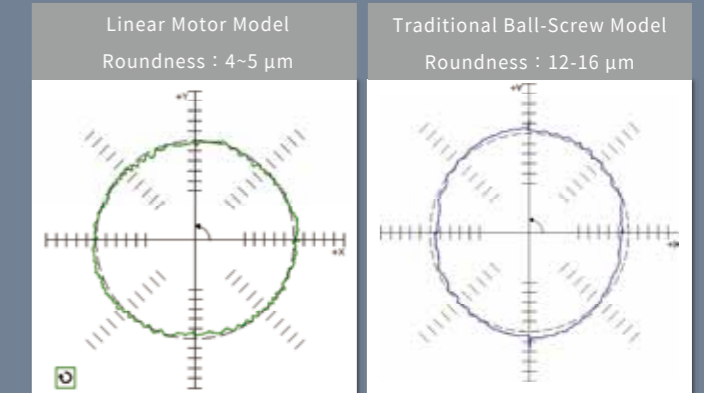

Linear Motor Achieves Superior Accuracy in Corner Transitions

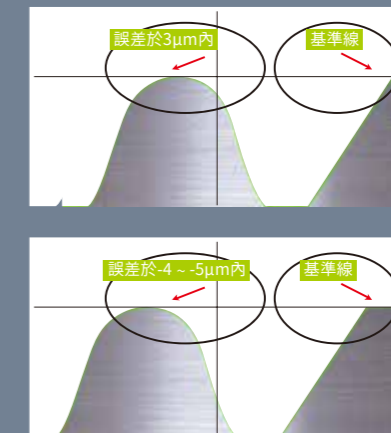

The intelligent i8+ power system boosts cutting speed by 15% while achieving 28% energy savings. It also features automatic discharge path optimization improving overall stability and reducing accuracy deviations.

15% CUTTING SPEED

ENERGY SAVING 28%

i8+ Power Supply

01 Discharge Control System

The system adopts an embedded architecture to reduce system load, while the FPGA chip enhances discharge performance. Cutting conditions are monitored and fed back in real time, ensuring stable discharge machining, resulting in up to 15% faster cutting speed.



02 Energy Recycling Technology Next-Generation

The new-generation i8+ power supply incorporates an advanced energy-saving circuit that recovers the back-EMF generated by high-speed, high-current feed lines and converts it back to reusable power, achieving up to 28% energy savings. In addition to energy regeneration, it also eliminates the excessive heat previously produced by discharging through SINK resistors, delivering true energy-saving and carbon-reduction performance.

03 IVC High-frequency Switching Inverter Power Supply



The upgraded IVC high-frequency switching inverter offers wide-range power output adjustment, allowing operators to fine-tune the discharge energy for better cutting performance and system safety.

It also adopts advanced filtering technology to reduce external interference and output more accurate energy pulses, ensuring precise discharge judgment and stable cutting performance.

High-efficiency Energy Management System

The NV Series integrates advanced power and water conservation technologies, slashing total energy consumption by up to 40%. Specifically, power usage is reduced by 28%, while the water system achieves savings of up to 45%.

Built-in energy recycling technology, achieving true energy recirculation. Furthermore, the use of IE3-grade variable frequency motors intelligently matches output to machining loads, ensuring maximum efficiency, superior stability, and significant energy savings.



71%

Water tank standby power cut by 71%.



45%

Inverter chiller power use reduced by 45%.



40%

Machining power cut by 40% vs. previous generation.



28%

Upgraded circuits lower power cabinet use by 28%.

01 Power Efficiency Comparison

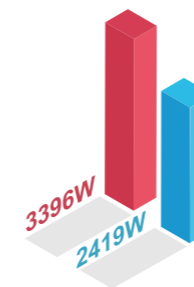

02 Standby Power Saving Comparison

Note: Under water tank power-on standby mode

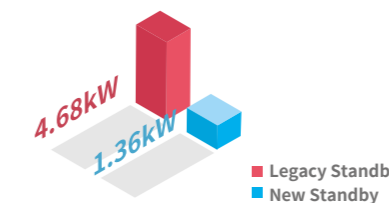

03 Eco Cut

Built-in Eco Cut mode reduces brass wire consumption by 42%.



04 Energy-saving Inverter Chiller

Equipped with automatic temperature detection and intelligent inverter control, the chiller improves cooling efficiency and maintains precise water temperature within $\pm 0.5^{\circ}\text{C}$. It ensures stable, high-accuracy machining while reducing power consumption by 45% compared with standard chillers.



05 Sleep Mode & Wake-up

Allows you to pre-set daily wake-up times for the equipment, enabling it to start up and execute production tasks immediately.



Precision Performance

High Accuracy + High Repeatability = High Stability

- Workpiece : SKD11
- Thickness : 20.0mm
- Wire Diameter : 0.25mm(Standard Brass Wire)
- Number of cuts : 3passes (1 rough cut + 2 skim cuts)
- Ambient Temperature : 23°C±0.5°C

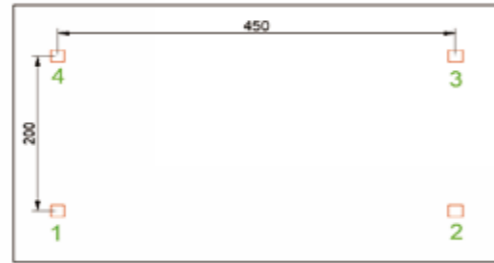

Positioning Accuracy – Pitch (mm)				Shape Accuracy – Cutting Shape (mm)				
Coordinate		Measured Deviation		Measured Deviation				
NO	X	Y	X	Y	NO	Square Hole	X	Y
1	0.00	0.00	0.0000	0.0000	1	8 x 8	0.0010	0.0008
2	450.00	0.00	-0.0018	-0.0001	2	8 x 8	0.0013	0.0010
3	450.00	200.00	-0.0022	0.0014	3	8 x 8	0.0012	0.0009
4	0.00	200.00	-0.0007	-0.0002	4	8 x 8	0.0008	0.0007
Min. Deviation mm			-0.0007	-0.0001	Min. Deviation mm		0.0008	0.0007
Max. Deviation mm			0.0022	0.0014	Max. Deviation mm		0.0013	0.0010

X-Axis Pitch Accuracy

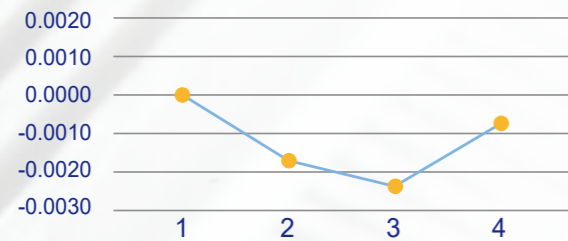

Y-Axis Pitch Accuracy

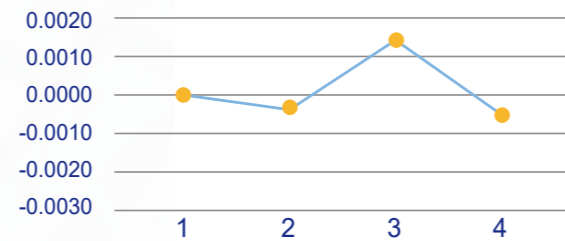

X-Axis Shape Accuracy

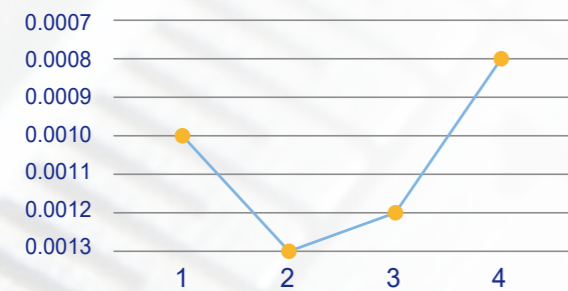

Y-Axis Shape Accuracy

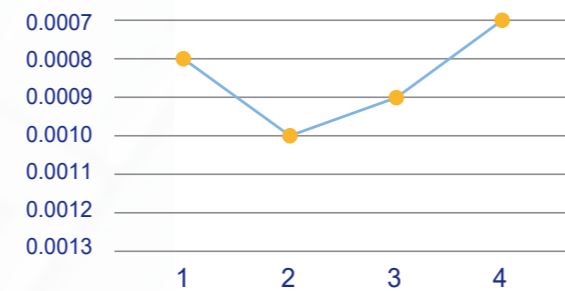

Roundness

- Diameter : 10.0017
- X : 0.0000
- Y : -0.0010
- Min [12] : -0.0008
- Max [27] : 0.0009
- Range : 0.0017
- Points : 32
- Magnification : 595
- Reference : 3



AC - μ Super Fine Finish Circuit (Opt.)

Applicable only to the NV432L model

AC-μ Super Fine Finish Circuit enables high-frequency discharge and precise energy control for superior surface quality :

- Best surface roughness: Ra 0.09 μm (Tungsten Carbide)
- Best surface roughness: Ra 0.12 μm (SKD11 Steel)



Material: SKD11 Wire Ø 0.20 mm Thickness: 50 mm							
Passes	6	5	4	3	2	1	
Surface Roughness (μm)	Ra	0.12	0.20	0.28	0.62	2.0	2.4
	Ry	1.1	1.7	2.5	5.0	13.3	14.3



Material: Tungsten Carbide Wire Ø 0.10 mm Thickness: 20 mm							
Passes	7	6	5	4	3	2	1
Surface Roughness (μm)	Ra	0.09	0.11	0.14	0.20	0.45	1.42
	Ry	0.8	1.0	1.2	1.6	3.3	10.2

01

AC/DC Power Supply

Designed for special metals such as titanium alloy and tungsten carbide, it suppresses electrolytic corrosion and oxidation during machining.



02

Corner Control Function

The unique corner control function enables precise machining of sharp corners with superior accuracy.

Conditions :

- Workpiece Material: SKD11
- Wire Diameter: Ø 0.20 mm
- Number of Cuts: 1
- Magnification: 150× Optical Projector

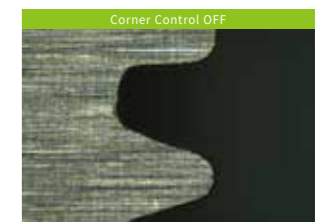
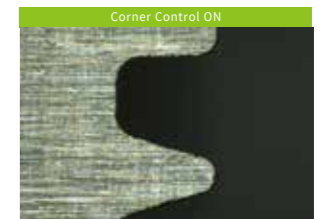

03

Power Cable Optimization

Equipped with the latest power cable, the system optimizes current density distribution. With intelligent anti-wire breakage control, it quickly and precisely eliminates abnormal discharges, significantly improving machining stability and accuracy.



Intelligent Power Master

AI-Powered CNC Wire Cut EDM

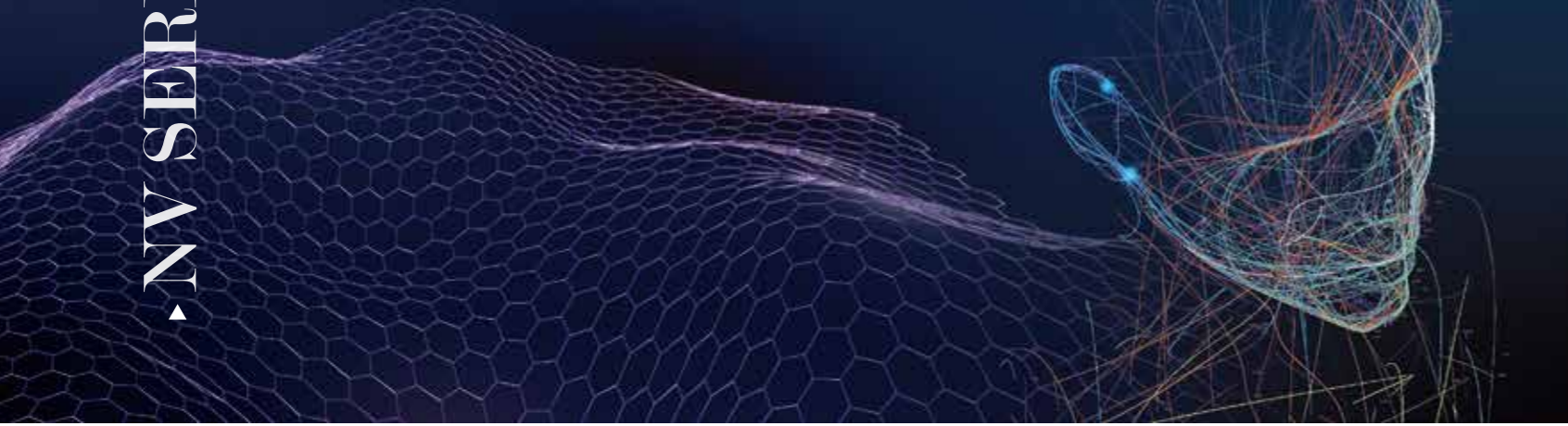

01

Intelligent Stepped Control (ISC) Power Supply (Opt.)

Through monitoring discharge waves, ISC can provide precise discharge control for stepped workpieces. It effectively prevents wire breakage, reduces wire marks, ensures high-speed and stable machining, and delivers high-quality finished parts.

Conditions: Workpiece: SKD11 Wire diameter: Ø0.25 mm

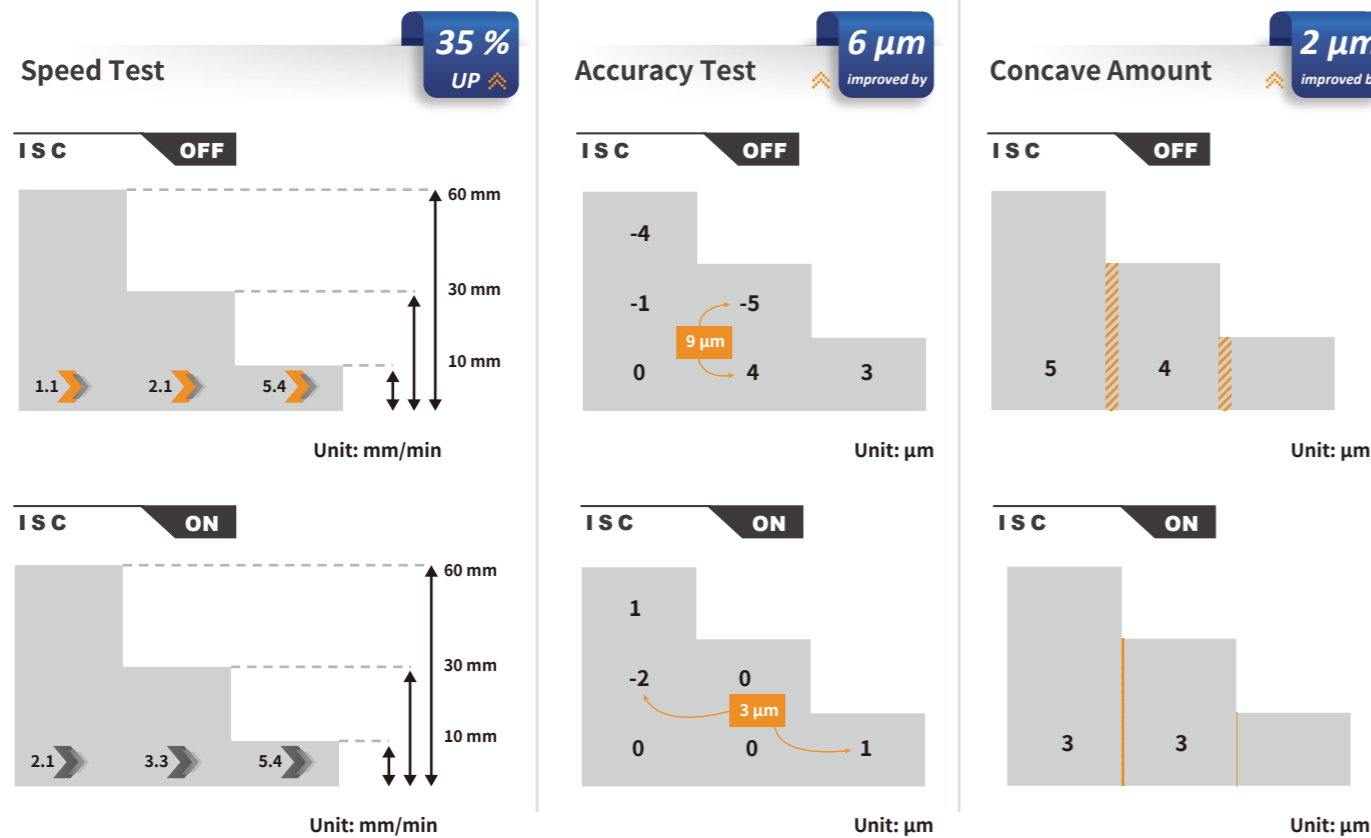

02

Corner Control

Integrating advanced AI technology, the system precisely predicts and dynamically adjusts cutting paths, achieving exceptional corner control with unmatched accuracy and surface finish. This technology significantly enhances machining efficiency and yield, meeting the rigorous quality demands of high-precision manufacturing.

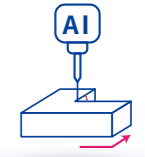

03

Intelligent Discharge Tracking

By integrating AI technology with real-time control, the system precisely monitors and adjusts discharge parameters on the fly. It effectively suppresses wire breakage while ensuring stable, efficient machining and consistent product quality.

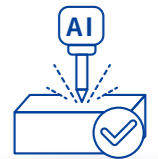

04

Intelligent Measurement

Powered by AI technology, the system precisely detects machining areas through probe or wire discharge sensing, automatically defining final machining dimensions. It retrieves optimized parameters from the machining database, enabling rapid setup and highly efficient machining.

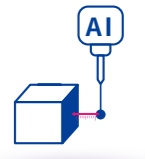

05

SAC – Super Hard Alloy Circuit

Designed for machining super hard alloy materials.

- Tungsten Carbide
- Nickel-Based Alloy
- Cobalt-Based Alloy
- Iron-Based Alloy
- Titanium Alloy
- Pure Tungsten

06

POS – Plane Offset System (Optional)

Uses a probe to measure the workpiece surface and compensates offset data to generate a true vertical plane.

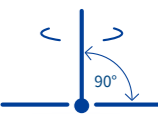

07

QMC – Surface Quality Master Circuit

It reduces wire marks at the lead-in and lead-out area on straight and curved cutting paths, ensuring smoother finishes and superior surface quality.

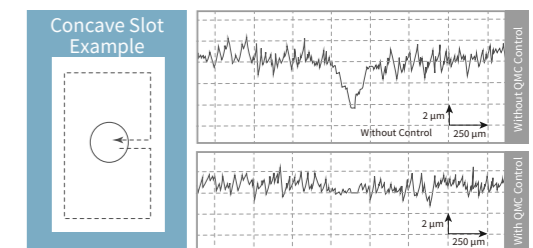

08

Taper Compensation System

Allows real-time taper compensation during machining and adjustment to any required angle.

In-House Controller

Features of the W5N Control System

The W5N GenOS controller integrates a Linux-based high-performance system with industrial PC technology, boosting computing power by over 15 times and supporting multi-axis synchronous control.

It features Database, FTP server, OPC UA server, and remote desktop functions for seamless data collection, remote monitoring, and MES system integration.

The modular hardware design improves maintenance convenience, enables quick upgrades, and facilitates efficient external device integration, ensuring long-term operational stability.



Intuitive Operation Interface

Simple and clear touch interface with guided navigation, allowing new users to operate quickly.



Preloaded Hole Machining Data

Stores up to 3,999 sets of machining data, with access to multiple hole-cutting parameters.



CAD/CAM Software (Opt.)

Supports 2D/3D graphics input, enabling direct toolpath conversion without additional processing steps for seamless execution.

01 Linux-Based OS

Independently developed Linux-based technology ensures high availability, stability, and reliability. It flexibly meets various operational needs without concerns about viruses or software licensing issues, delivering optimal performance across different applications.

02 Digital Water Pressure Adjustment

The digital water pressure system features automatic adjustment, allowing precise pressure and flow rate control based on actual machining needs, ensuring process stability.

03 QR Code Program Input

Utilizes QR code scanning for quick input of program calls and machining parameters, streamlining pre-processing setup while reducing manual input time and error rates.

04 EtherCAT Communication

Combining EtherCAT automation with GenOS enables high-speed response and scalability, meeting multi-axis synchronized motion control needs. Supports up to 7-axis EtherCAT communication and discharge modules, boosting computing performance 15×.

05 Temperature Monitoring

Integrated temperature sensors and control system monitor equipment operating temperatures in real time. Data collected by sensors provides instant temperature feedback, enabling thermal compensation to maintain optimal operating conditions. Supports preventive maintenance strategies to enhance efficiency and stability.

06 Enhanced Performance

From graphical data loading to pre-machining simulation, the controller's computation time has improved 15× compared to the previous generation.

New vs. Old Controller Comparison				
Item	Unit	F-Type	N-Type	Difference
Computing Performance	FLOPs	806	12135	↑ 15×
Size	LxHxW cm	28.5x20.5x30.5	19.4x14.8x6	↓ 90%
Weight	kg	9.05	1	↓ 90%
Power Consumption	W	44	13.44	↓ 70%
Component Count	pcs	159	12	↓ 92%
Overall Assembly Size	kg	105	84	↓ 20%
100MB File Loading Speed	s	31.8/36.5	2.9/2.7	↑ 12×



Mobile Technology and Optimal Intelligence (Opt.)

Without standing in front of the machine, the all new “Remote monitoring & IoT” can connect to the Cloud through various mobile devices.

The intelligent Cloud function creates a perfect mobile management platform and gives you a foreseeable future and a new era of intelligent machinery.

With the core technology of intelligent information management center, the IoT can collect the data and history of every machine, for instance, the relation between power, temperature, and time, and can observe the characteristic data by time. The customer can own a database of big data.

Under the intelligent information management center, we develop two kinds of software service platform for easy and convenient management system, including

- Mobile Data Platform
- iConnected Information Management Center

You can choose the suitable platform among different service platforms.

Information Management Center - Features



Data Visualization

Real-time machine data is displayed, retrieved from the machine's database, and converted into pie charts and line graphs, using data visualization for production line analysis.



Active Push Notifications

CHMER's smart push notification system is perfectly integrated with the alarm system, allowing you to monitor machine status anytime, anywhere.

Whether dining, resting, socializing, or on vacation, you will receive notifications instantly on your phone or tablet.

In the Industry 4.0 era, this system significantly shortens problem response time, reduces cost losses, minimizes manpower for on-site monitoring, and enhances overall operational efficiency.

Information Management Center - Includes

01



Mobile Data Platform

Offers mobile management capabilities, allowing instant access to various machine information, such as machine status, uptime, consumable life management, and real-time machining monitoring, through phones or tablets.

02



Intelligent Information Management Center

Stores large amounts of machine data every second, viewable through historical data query pages, allowing the resolution of the following issues:

- a. Understanding machine uptime (critical for customers)
- b. Knowing consumable usage (helps customers know when to replace consumables)
- c. Conducting detailed analysis of machine operation (retrieve alarms during specific timeframes, and know the machine's status at the time to further analyze)





**MEDICAL
INDUSTRY**

Lumbar Intervertebral Cage



**AUTOMOTIVE
INDUSTRY**

Transmission System Mold

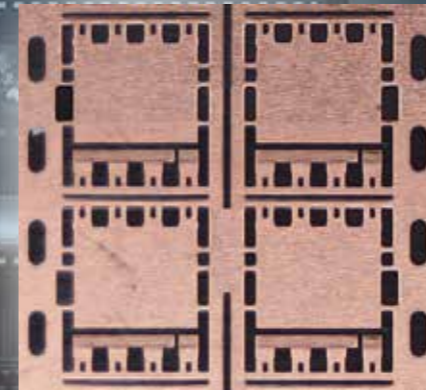

**ELECTRONICS
INDUSTRY**

Lead Frame Stamping Molds

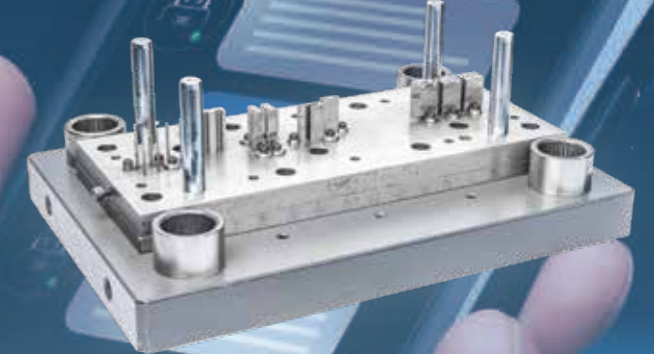

**ICT
INDUSTRY**

Precision Connector Stamping Molds

Standard/Optional

Standard ● Optional ○ Not Available —

Features & Item	Specification	Unit	NV432L	NV643L
Power Supply & Control System				
I8+ Power Supply		1 set	●	●
AC/DC Power		1 set	●	●
Intelligent Stepless Control Power		1 set	○	○
Super Fine Finish Circuit		1 set	●	○
Touch Screen	24"	1 set	●	●
Interrupted Power Recovery		1 set	●	●
USB		1 set	●	●
Internet Data Transfer		1 set	●	●
DXF Transferring Function		1 set	●	●
Remote Monitoring & Internet Connection		1 set	○	○
Mechanism & Machining System				
UX1 Linear Motor Drive System	CHMER X & Y Axes	1 set	●	●
Absolute Linear Scale	0.1 μm resolution	1 set	●	●
Automatic Wire Threading System	AWT 6.0	1 set	●	●
Wire Diameter Machining	Ø 0.15~0.30 mm	1 set	●	●
Fine Wire Specification	Ø 0.1 mm	1 set	○	○
Wire Threading Assistant Device		1 set	●	●
Z-Axis Travel Extension		1 set	○	-
Z-Axis Travel Extension		1 set	-	○
Automatic Rise-and-Fall Door		1 set	●	●
Intelligent Water Level Control System	IWA	1 set	●	●
High Efficient Water Circulation System		1 set	●	●
Energy Saving Inverter Chiller	20000 BTU	1 set	●	●
Additional Functions				
Temperature Monitoring Device		5 set	●	●
Digital Water Pressure Adjustment		1 set	●	●
6th Axis Machining		1 set	○	○
Jumbo Wire Feeder	30 kg	1 set	○	○
Auto Wire Chopper	Ø ≤ 0.1 mm Not Usable	1 set	○	○
2 in 1 Transformer and AVR		1 set	○	○
Waste Adhesion Prevention		1 set	●	●
Sleep Mode & Wake-up		1 set	●	●
Wire Overflow Protection		1 set	●	●
QR Code Program Input		1 set	●	●
Taper Compensation System		1 set	●	●
POS – Plane Offset System		1 set	○	○
QMC-Surface Quality Control Circuit		1 set	●	●
CAD/CAM		1 set	○	○

Standard/Optional Features



Patented Automatic Rise and Fall Front Door

Best protection and automatically rise and fall door to match the loading and unloading workpiece by automation



Energy-Saving Inverter Chiller

Autonomous temperature detection, smart variable frequency, and fast cooling precisely control water temperature to ±0.5°C, ensuring stable processing with 45% lower power consumption than standard chillers.



DXF Transferring Function

CHMER self-developed software can convert drawing to program



Sleep Mode & Wake-up

Allows you to pre-set daily wake-up times for the equipment, enabling it to start up and execute production tasks immediately.

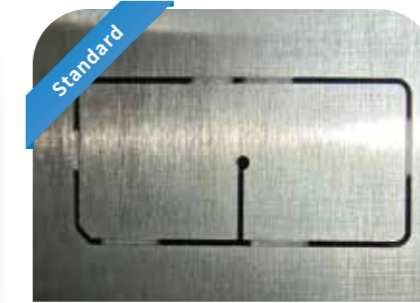

Waste Adhesion Prevention

During machining, the welding function can be applied to prevent scrap pieces from falling. After machining is completed, the scrap can be removed manually, thereby improving machine utilization.



The 6th Axis

Equipped with IP68 protection, the 6th-axis supports underwater 3D machining, enabling complex surfaces and rotational angles for broader applications and greater added value.



Jumbo Wire Feeder

30 kg wire spool provides long time cutting for unmanned operation



POS Plane Offset System

Equipped with a probe measurement system, POS compensates for deviation and converts it into a true vertical plane after calculation.



Auto Wire Chopper

The wire cutting device cuts waste wire into sections, increasing waste box space utilization by over 100% compared to traditional methods where wire is wound in a continuous coil.

Standard Specifications

Model	NV432L	NV643L
X, Y, Z Travel	mm 400 x 300 x 250	600 x 400 x 310
U, V Travel	mm 100 x 100	120 x 120
Max. Workpiece Size	mm 725 x 600 x 245 (Submerged)	900 x 700 x 305 (Submerged)
Max. Workpiece Weight	kg 500	800
X, Y Feedrate	mm/min 1800	1800
Axis Drive System	XY Axes Linear Motor Drive/ UVZ Axes AC Servo Motor Drive	
Wire Diameter (Standard)	mm $\varnothing 0.15 \sim 0.3 (\varnothing 0.25)$	
Wire Tension	gf 300 ~ 2500	
Max. Wire Feeding Speed	mm/sec 300	
Wire Feeder Load Capacity	kg ≤ 8	
Max. Cutting Taper	mm $\pm 21^\circ/110$ (Wide Angle Nozzle · DA+DB=15 mm) $\pm 21^\circ/140$ (Wide Angle Nozzle · DA+DB=15 mm)	
Machine Dimension (WxDxH)	mm 2720 x 2300 x 2350	3040 x 2560 x 2415
Net Weight	kg 3200	4100

Dielectric Filtration System		
Dielectric Capacity	L 1250	1,250
Filter	Paper	Paper
Ion Exchange Resin Filter	L 20	20
Water Quality Control	Auto	Auto
Water Temperature Control	Auto	Auto

Power Supply Unit		
Circuit Type	Transistor, No Resistance Loop	
Discharge Mode	Rough Machining / Fine Machining / AC- μ Super Fine Finish	
Discharge Voltage Levels	16 (Standard) / 20 (Optional)	
Discharge Time Levels	60	
Pause Time Levels	233	

CNC Unit			
Controller Version	N-Type Controller	Compensation Functions	Linear / Circular
Operating System	GenOS (LINUX)	Position Command	Absolute / Incremental
Processor	32 bit	Command Unit	Metric / Inch
CPU Core Count	Quad-core	Machining Speed Control	Servo / Fixed
RAM	4 GB	Interpolation Rate	0.001-9999.999
Storage	32 GB	Program Storage Capacity	1000-9999
Display	24" Color Touch Screen	Power Input	3 Phase 220V $\pm 5\%$
Servo Control	EtherCAT - Semi-closed Loop, Fully-closed Loop (Optical Encoder)	Max Input Power	8 kVA
Controlled Axes	5 / 7 Axes: X, Y, U, V, Z (Optional Rotary Axis)	Input Method	Keyboard, RS232C, RS422, RS485, USB, LAN
Resolution Unit	0.0001 mm		
Max Display Value	± 9999.9999 mm		

Floor Layout

NV432L

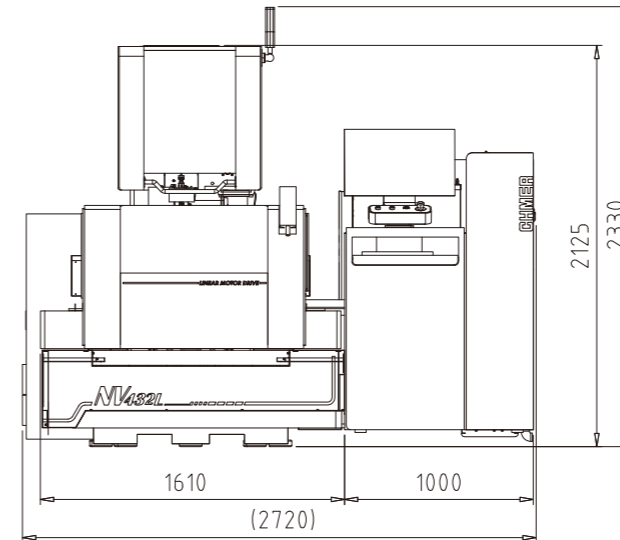
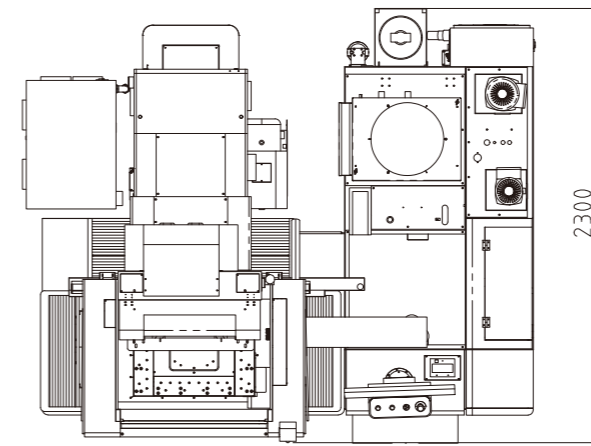

Worktable Hole Layout

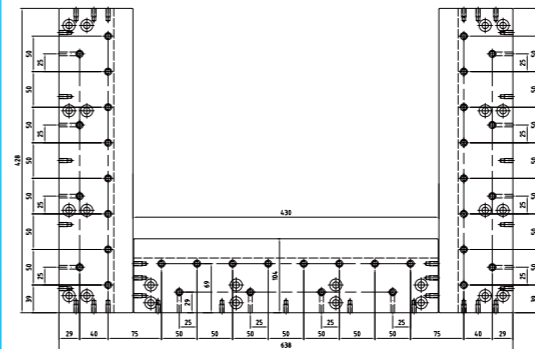

NV643L

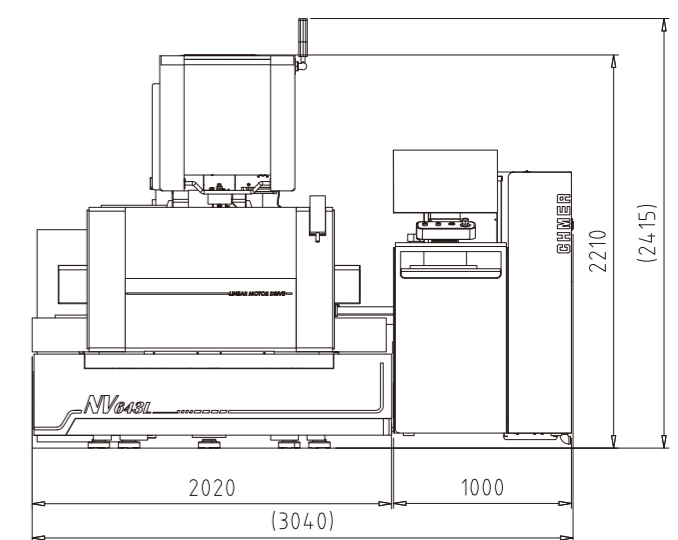
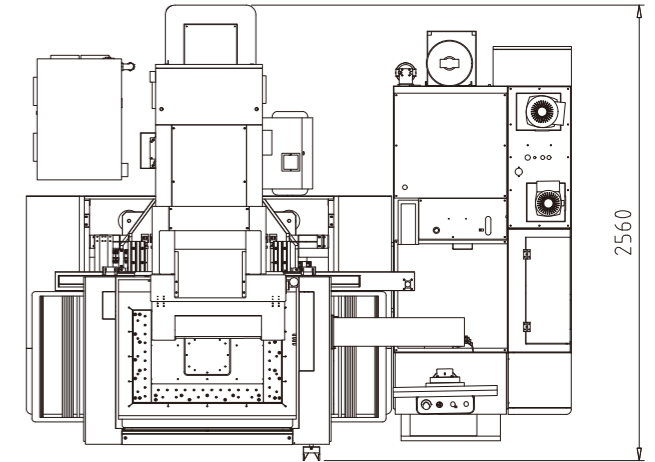

Worktable Hole Layout

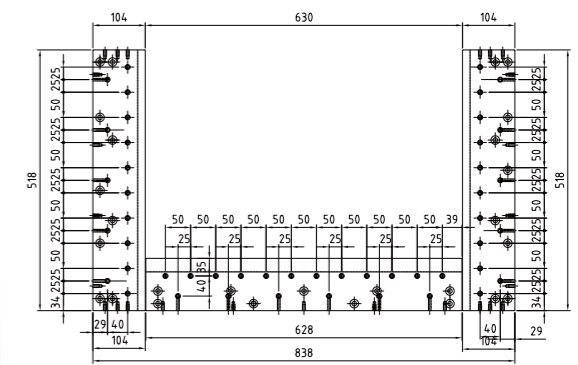

※Due to continuous improvements, the design and specifications are subject to change without prior notice.